

Front Suspension

Steering System:

Swing Rack Bellcrank Rack

Anti Roll Bar:

2.2mm Green
 2.3mm White
 2.4mm Blue
 2.5mm Yellow

Bumpsteer Washers: _____

Camber: _____

Caster: _____

Toe: _____

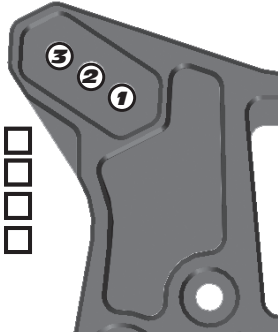

Upper Hinge Pin Bushing

Front # _____
 Up Down

Rear # _____
 Up Down

B-Plate Type

Low Original

Kickup Bushing A-Plate

 Up Down

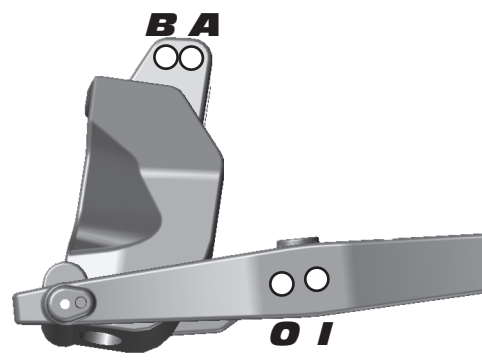

Ride Height: _____

Rear Suspension

Wheelbase:

Long
 Medium
 Short

Anti Roll Bar:

2.5mm Green
 2.6mm White
 2.7mm Blue
 2.8mm Yellow

Camber: _____



Toe Bushing D-Plate

 In Out

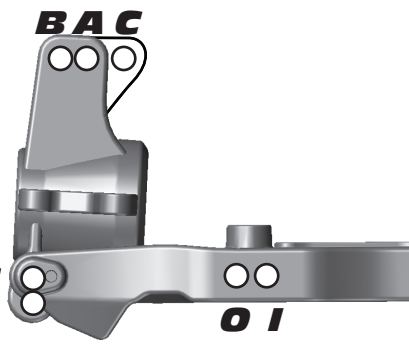

Squat Bushing C-Plate

 Up Down

Ride Height: _____

Front Shocks

Spring: _____ Shock Cap: _____
 Shock Fluid: _____ Length: _____
 Piston: _____ Rebound: _____

Rear Shocks

Spring: _____ Shock Cap: _____
 Shock Fluid: _____ Length: _____
 Piston: _____ Rebound: _____

Chassis Braces / Wheel Hex

Chassis Braces: Wheel Hex:
 Pivot Standard
 Molded Narrow
 Aluminum

Chassis Weight

Weight: _____

Rear Hubs

Rear Hubs: Standard
 CNC FT Alum.

Differentials

Front Diff Fluid: _____
 Center Diff Fluid: _____
 Rear Diff Fluid: _____

Body / Wing

Body Type: _____
 Wing Type: _____
 Gap to Tower (MM): _____

Gearing / Clutch

Spur Gear: _____
 Clutch Bell: _____
 Clutch Shoes: _____
 Clutch Spring: _____

Engine

Engine: _____
 Restrictor: _____ Temp: _____
 Muffler: _____
 Glow Plug: _____ Fuel: _____

Tires

Tire (F/R): _____ / _____
 Compound (F/R): _____ / _____
 Inserts (F/R): _____ / _____
 Wheel (F/R): _____ / _____
 Notes: _____

Radio / Servos

Radio: _____ Brake Bias: _____
 Throttle / Steering Servo: _____ / _____
 Throttle / Brake expo: _____ / _____
 Steering expo: _____
 Dual Rate: _____

Race and Vehicle Comments

Qualify: _____ Main: _____ Finish: _____ TQ: _____
 Comments: _____

Track Info

Traction: High Medium Low
 Surface: Smooth Bumpy Blue Groove
 Soft Dirt Grass Clay Wet
 Astroturf Dusty Other: _____